

YASKAWA AC Drive - 1000-Series Option
Metasys N2 & APOGEE FLN P1
Installation & Technical Manual

Type: SI-J3

To properly use the product, read this manual thoroughly and retain for easy reference, inspection, and maintenance. Ensure the end user receives this manual.

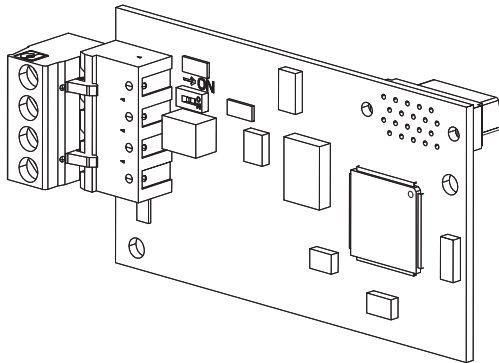

Copyright © 2013 YASKAWA AMERICA, INC. All rights reserved.

All rights reserved. No part of this publication may be reproduced, stored in a retrieval system, or transmitted, in any form or by any means, mechanical, electronic, photocopying, recording, or otherwise, without the prior written permission of Yaskawa. No patent liability is assumed with respect to the use of the information contained herein. Moreover, because Yaskawa is constantly striving to improve its high-quality products, the information contained in this manual is subject to change without notice. Every precaution has been taken in the preparation of this manual. Yaskawa assumes no responsibility for errors or omissions. Neither is any liability assumed for damages resulting from the use of the information contained in this publication.

Table of Contents

1	PREFACE AND SAFETY.....	4
2	PRODUCT OVERVIEW.....	8
3	RECEIVING.....	9
4	OPTION COMPONENTS.....	10
5	INSTALLATION PROCEDURE.....	13
6	RELATED DRIVE PARAMETERS.....	23
7	NETWORK DRIVE OPERATIONS.....	25
8	COMMUNICATIONS TIMING.....	26
9	METASYS N2 COMMUNICATIONS.....	28
10	APOGEE FLN P1 COMMUNICATIONS.....	36
11	TROUBLESHOOTING.....	46
12	OPTION ERROR CODES.....	50
13	OPTION COMPATIBILITY.....	51
14	SPECIFICATIONS.....	53

1 Preface and Safety

Yaskawa manufactures products used as components in a wide variety of industrial systems and equipment. The selection and application of Yaskawa products remain the responsibility of the equipment manufacturer or end user. Yaskawa accepts no responsibility for the way its products are incorporated into the final system design. Under no circumstances should any Yaskawa product be incorporated into any product or design as the exclusive or sole safety control. Without exception, all controls should be designed to detect faults dynamically and fail safely under all circumstances. All systems or equipment designed to incorporate a product manufactured by Yaskawa must be supplied to the end user with appropriate warnings and instructions as to the safe use and operation of that part. Any warnings provided by Yaskawa must be promptly provided to the end user. Yaskawa offers an express warranty only as to the quality of its products in conforming to standards and specifications published in the Yaskawa manual. **NO OTHER WARRANTY, EXPRESS OR IMPLIED, IS OFFERED.** Yaskawa assumes no liability for any personal injury, property damage, losses, or claims arising from misapplication of its products.

◆ Applicable Documentation

The following manual is available for the SI-J3 option:

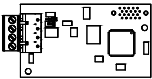
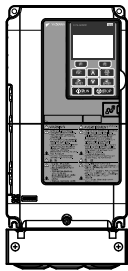
SI-J3 Option	
	<p>Yaskawa AC Drive 1000-Series Option Metasys N2 & APOGEE FLN P1 SI-J3 Installation and Technical Manual (TOEPYAICOM13)</p> <p>The installation manual is packaged with the SI-J3 option and contains detailed information required to install the option and set up related drive parameters. This manual also contains information about troubleshooting procedures and supported objects.</p>
Yaskawa Drive	
	<p>1000-Series AC Drive Quick Start Guide or User Manual</p> <p>The quick start guide is packaged together with the product and contains basic information required to install and wire the drive. It also gives an overview of fault diagnostics, maintenance, and parameter settings. The purpose of this guide is to prepare the drive for a trial run with an application and for basic operation. This manual is available for download on our documentation website, www.yaskawa.com.</p>
	<p>1000-Series AC Drive Technical Manual</p> <p>The technical manual provides detailed information on parameter settings, drive functions, and MEMOBUS/Modbus specifications. Use this manual to expand drive functionality and to take advantage of higher performance features. This manual is available for download on our documentation website, www.yaskawa.com.</p>

◆ Terms

Note: Indicates supplemental information that is not related to safety messages.

Drive: Yaskawa 1000-Series Drive

Option: Yaskawa AC Drive 1000-Series, Metasys N2 and APOGEE P1 SI-J3 Option

◆ Registered Trademarks

All trademarks are the property of their respective owners.

◆ Supplemental Safety Information

Read and understand this manual before installing, operating, or servicing this option. The option must be installed according to this manual and local codes.

The following conventions are used to indicate safety messages in this manual. Failure to heed these messages could result in serious or possibly even fatal injury or damage to the products or to related equipment and systems.

WARNING

Read and understand this manual before installing, operating or servicing this drive. The drive must be installed according to this manual and local codes.

The following conventions are used to indicate safety messages in this manual. Failure to heed these messages could result in serious or fatal injury or damage to the products or to related equipment and systems.

DANGER

Indicates a hazardous situation, which, if not avoided, will result in death or serious injury.

WARNING

Indicates a hazardous situation, which, if not avoided, could result in death or serious injury.

1 Preface and Safety

WARNING! may also be indicated by a bold key word embedded in the text followed by an italicized safety message.

CAUTION

Indicates a hazardous situation, which, if not avoided, could result in minor or moderate injury.

CAUTION! may also be indicated by a bold key word embedded in the text followed by an italicized safety message.

NOTICE

Indicates a property damage message.

NOTICE: may also be indicated by a bold key word embedded in the text followed by an italicized safety message.

■ General Safety

General Precautions

- The diagrams in this manual may be indicated without covers or safety shields to show details. Replace the covers or shields before operating the drive and run the drive according to the instructions described in this manual.
- Any illustrations, photographs, or examples used in this manual are provided as examples only and may not apply to all products to which this manual is applicable.
- The products and specifications described in this manual or the content and presentation of the manual may be changed without notice to improve the product and/or the manual.
- When ordering a new copy of the manual due to damage or loss, contact your Yaskawa representative or the nearest Yaskawa sales office and provide the manual number shown on the front cover.
- Order a replacement from your Yaskawa representative or the nearest Yaskawa sales office if nameplate becomes worn or damaged.

DANGER

Heed the safety messages in this manual.

Failure to comply will result in death or serious injury.

The operating company is responsible for any injuries or equipment damage resulting from failure to heed the warnings in this manual.

DANGER

Electrical Shock Hazard

Do not connect or disconnect wiring while the power is on.

Failure to comply will result in death or serious injury.

Failure to comply will result in death or serious injury. Before servicing, disconnect all power to the equipment. The internal capacitor remains charged even after the power supply is turned off. The charge indicator LED will extinguish when the DC bus voltage is below 50 Vdc. To prevent electric shock, wait for at least the time specified on the warning label once all indicators are OFF, and then measure the DC bus voltage level to confirm it has reached a safe level.

NOTICE

Observe proper electrostatic discharge procedures (ESD) when handling the drive and circuit boards.

Failure to comply may result in ESD damage to the drive circuitry.

Do not perform a withstand voltage test on any part of the drive.

Failure to comply could result in damage to the sensitive devices within the drive.

Do not operate damaged equipment.

Failure to comply could result in further damage to the equipment.

Do not connect or operate any equipment with visible damage or missing parts.

Do not expose the drive to halogen group disinfectants.

Failure to comply may cause damage to the electrical components in the drive.

Do not pack the drive in wooden materials that have been fumigated or sterilized.

Do not sterilize the entire package after the product is packed.

2 Product Overview

◆ About this Product

The SI-J3 option connects 1000 series drives to a Metasys N2 or APOGEE FLN P1 network and facilitates the exchange of data.

This manual explains the handling, installation and specifications of this product. The SI-J3 option is a simple, networking solution that reduces the cost and time to wire and install factory automation devices, while providing interchangeability of like components from multiple vendors.

Drives can be monitored and controlled by a controller on a Building Automation and Control network using RS-485 technology and the Metasys N2 or the APOGEE FLN P1 protocol.

Up to 255 drives can communicate on a single network.

◆ Applicable Models

The option can be used with the drive models in [Table 1](#).

Table 1 Applicable Models

Drive Series	Drive Model Number	Software Version <1>
P1000	CIMR-PU□A□□□□□□□□	VSP908502 and later
iQpump1000	CIMR-PW□A□□□□□□□□	VSA908550 and later





<1> See PRG on the drive nameplate for the software version number.

3 Receiving

Please perform the following tasks upon receipt of the option:

- inspect the option for damage. Contact the shipper immediately if the option appears damaged upon receipt
- verify receipt of the correct model by checking the model number printed on the name plate of the option package
- contact your supplier if you have received the wrong model or the option does not function properly.

◆ Option Package Contents

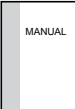
Description	Option PCB PN: UTC00063□	Ground Wire	Screws (M3)	LED Label	Installation Manual
-					
Quantity	1	1	3	1	1

◆ Tools Required for Installation

- A Phillips screwdriver (M3 metric/#1 or #2 U.S. standard size) is required to install the option and remove drive front covers. Screw sizes vary by drive capacity. Select a screwdriver appropriate for the drive capacity.
- Diagonal cutting pliers. (required for some drive models)
- A small file or medium grit sandpaper. (required for some drive models)
- A straight-edge screwdriver (blade depth: 0.4 mm, width: 2.5 mm) is required to wire the option terminal block.

Note: Tools required to prepare option networking cables for wiring are not listed in this manual.

4 Option Components

◆ SI-J3/Metasys N2 or APOGEE FLN P1 Option

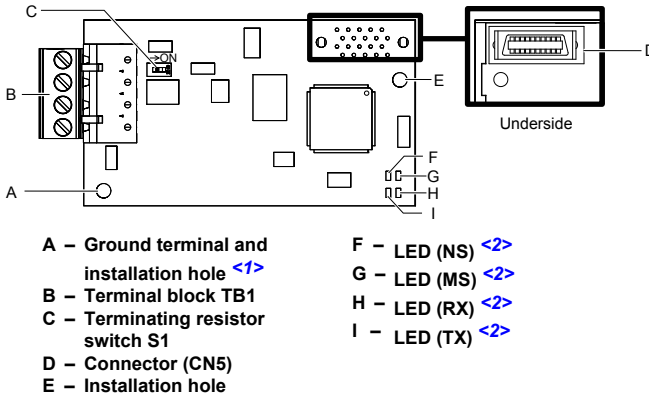

Figure 1 Option (Top View)

- <1> Connect the ground wire provided in the option shipping package during installation.
- <2> Refer to [Option LED Display on page 11](#) for details on the LEDs.

◆ Terminal Block TB1

Refer to [Table 2](#) for details on removable terminal block TB1 terminal descriptions.

Table 2 Option Terminal Descriptions

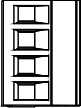
Terminal	Pin	Signal	Description
	1	IG5	Isolated supply ground reference
	2	+	RX/TX (+) signal
	3	-	RX/TX (-) signal
	4	SHLD	Shield Ground

◆ Option LED Display

The option has four LEDs.

Two bi-color Status LEDs:

- Module status (MS) red/green
- Network status (NS) red/green

Two Network LEDs:

- Transmit (TX) green
- Receive (RX) green

The operational states of the option LEDs after completion of the power-up diagnostic LED sequence are described in [Table 3](#). Wait at least 2 seconds for the power-up diagnostic process to complete before verifying LED states.

Table 3 Option LED States

Name	Display		Operating Status	Remarks
	Color	Status		
MS	-	OFF	Power supply OFF	Power is not being supplied to the drive.
	Green	ON	Normal operation	The option is operating normally and initialization is complete.
	Green	Flashing	Standby/Initializing	The option is in process of configuring or waiting for configuration information.
	Red	Flashing	Minor fault	The option has detected a recoverable minor fault such as incomplete configuration.
	Red	ON	Major fault	The option has detected an unrecoverable major fault.
	Green/Red	Flashing	Option self-test	The option is in self-test mode.
NS	-	OFF	Power supply OFF	-
	Green	ON	Connected	The device is currently communicating on the network.
	Green	Flashing	Not connected	The device currently is not communicating, but is correctly configured. The state is waiting for communication to resume.
	Red	Flashing	Minor fault	A minor recoverable fault has occurred.
	Red	ON	Major fault	A non-recoverable major network fault has occurred.
	Green/Red	Flashing	Network test	Power-up sequence and testing
TX	-	OFF	No data being sent to the network	This node is not sending any data.
	Green	Flashing	Data being sent to the network	This node is sending network data.

4 Option Components

Name	Display		Operating Status	Remarks
	Color	Status		
RX	-	OFF	No data seen on the network	The option is not physically connected to the network or there is no network activity.
	Green	Flashing	Data is seen on the network	The option is connected to a network.

■ Power-Up Diagnostics

An LED test is performed each time the drive is powered up. The initial boot sequence may take several seconds. After the LEDs have completed the diagnostic LED sequence, the option is successfully initialized. The LEDs then assume operational conditions as shown in

[Table 3](#).

Table 4 Power-Up Diagnostic LED Sequence

Sequence	Time	Module Status (MS)	Network Status (NS)	Tx	Rx
1	Initial	OFF	OFF	OFF	OFF
2	0.25 seconds	Green	OFF	OFF	OFF
3	0.25 seconds	Red	OFF	OFF	OFF
4	0.25 seconds	OFF	Green	OFF	OFF
5	0.25 seconds	OFF	Red	OFF	OFF
6	0.25 seconds	OFF	OFF	Green	OFF
7	0.25 seconds	OFF	OFF	OFF	Green
8	Run Time	Go to proper state	Go to proper state	Go to proper state	Go to proper state

5 Installation Procedure

◆ Section Safety

DANGER

Electrical Shock Hazard

Do not connect or disconnect wiring while the power is on.

Failure to comply will result in death or serious injury.

Before installing the option, disconnect all power to the drive. The internal capacitor remains charged even after the power supply is turned off. The charge indicator LED will extinguish when the DC bus voltage is below 50 Vdc. To prevent electric shock, wait at least five minutes after all indicators are off and measure the DC bus voltage level to confirm safe level.

WARNING

Electrical Shock Hazard

Do not operate equipment with covers removed.

Failure to comply could result in death or serious injury.

The diagrams in this section may show drives without covers or safety shields to show details. Be sure to reinstall covers or shields before operating the drives and run the drives according to the instructions described in this manual.

Do not remove covers or touch circuit boards while the power is on.

Failure to comply could result in death or serious injury.

Do not allow unqualified personnel to use equipment.

Failure to comply could result in death or serious injury.

Installation, maintenance, inspection, and servicing must be performed only by authorized personnel familiar with installation, adjustment, and maintenance of this product.

5 Installation Procedure

WARNING

Do not touch any terminals before the capacitors have fully discharged.

Failure to comply could result in death or serious injury.

Before installing the option, disconnect all power to the drive. The internal capacitor remains charged even after the power supply is turned off. The charge indicator LED will extinguish when the DC bus voltage is below 50 Vdc. To prevent electric shock, wait at least five minutes after all indicators are off and measure the DC bus voltage level to confirm safe level.

Do not use damaged wires, stress the wiring, or damage the wire insulation.

Failure to comply could result in death or serious injury.

Fire Hazard

Tighten all terminal screws to the specified tightening torque.

Loose electrical connections could result in death or serious injury by fire due to overheating of electrical connections.

NOTICE

Observe proper electrostatic discharge procedures (ESD) when handling the drive and circuit boards.

Failure to comply may result in ESD damage to the drive circuitry.

Do not use unshielded cable for control wiring.

Failure to comply may cause electrical interference resulting in poor system performance. Use shielded, twisted-pair wires and ground the shield to the designated shield ground location.

Check all the wiring to ensure that all connections are correct after installing the option and connecting any other devices.

Failure to comply could result in damage to the option.

Prior to Installing the Option

Prior to installing the option, wire the drive, make necessary connections to the drive terminals, and verify that the drive functions normally without the option installed. Refer to the Quick Start Guide packaged with the drive for information on wiring and connecting the drive.

Figure 2 shows an exploded view of the drive with the option and related components for reference.

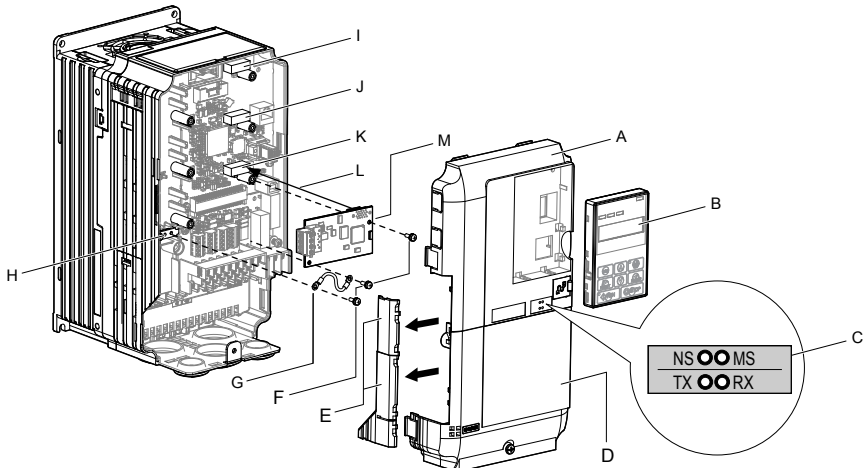

- | | |
|-------------------------------------|---------------------------------------|
| A – Drive front cover | H – Drive grounding terminal (FE) |
| B – Digital operator | I – Connector CN5-C |
| C – LED label | J – Connector CN5-B |
| D – Drive terminal cover | K – Connector CN5-A |
| E – Removable tabs for wire routing | L – Insertion point for CN5 connector |
| F – Included screws | M – SI-J3 option |
| G – Ground wire | |

Figure 2 Drive Components with Option

◆ Installing the Option

Remove the front covers of the drive before installing the option. Refer to the drive Quick Start Guide for directions on removing the front covers. Cover removal varies depending on drive size. This option can be inserted only into the CN5-A connector located on the drive control board.

Preparing the Drive

1. Shut off power to the drive, wait the appropriate amount of time for voltage to dissipate, then remove the digital operator (B) and front covers (A, D). Front cover removal varies by model.

DANGER! *Electrical Shock Hazard. Do not connect or disconnect wiring while the power is on. Failure to comply will result in death or serious injury. Before installing the option, disconnect all power to the drive. The internal capacitor remains charged even after the power supply is turned off. The charge indicator LED will extinguish when the DC bus voltage is below 50 Vdc. To prevent electric shock, wait at least five minutes after all indicators are off and measure the DC bus voltage level to confirm safe level.*

5 Installation Procedure

NOTICE: *Damage to Equipment.* Observe proper electrostatic discharge procedures (ESD) when handling the option, drive, and circuit boards. Failure to comply may result in ESD damage to circuitry.

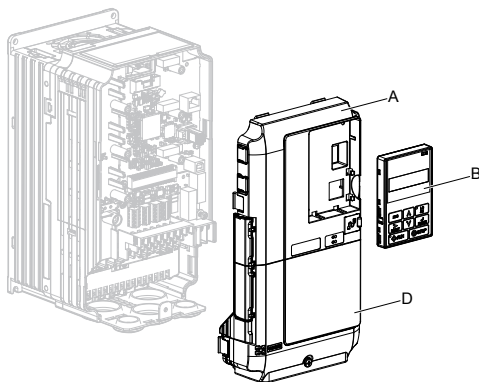

Figure 3 Remove the Front Covers and Digital Operator

2. With the front covers and digital operator removed, apply the LED label (C) in the appropriate position on the drive top front cover (A).

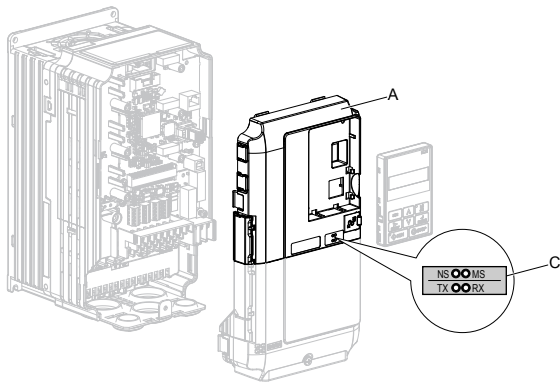

Figure 4 Apply the LED Label

Connecting Option and Ground Wire

1. Insert the option (M) into the **CN5-A** connector (K) located on the drive and fasten it using one of the included screws (F).

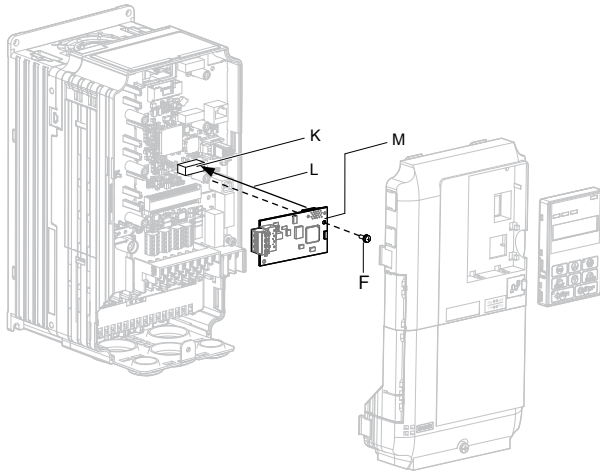

Figure 5 Insert the Option

2. Connect the ground wire (G) to the ground terminal (H) using one of the remaining provided screws (F). Connect the other end of the ground wire (G) to the remaining ground terminal and installation hole on the option (M) using the last remaining provided screw (F) and tighten both screws to 0.5 ~ 0.6 N m or (4.4 ~ 5.3 in lbs).

5 Installation Procedure

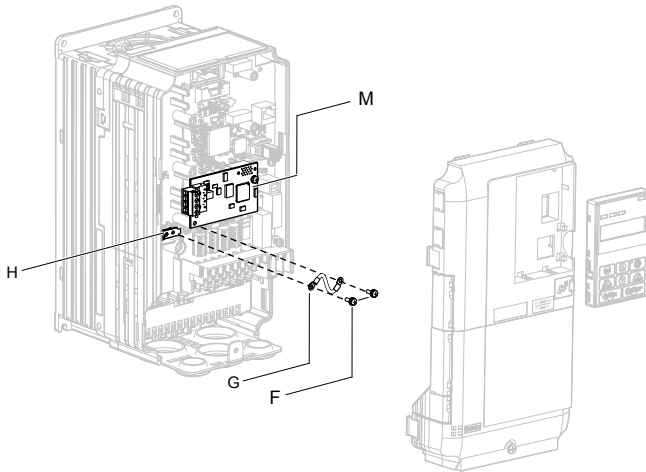

Figure 6 Connect the Ground Wire

Note: There are two screw holes on the drive for use as ground terminals. When connecting three options, two ground wires will need to share the same drive ground terminal.

Wiring the Option

1. Route the option wiring.

Depending on the drive model, some drives may require routing the wiring through the side of the front cover to the outside to provide adequate space for the wiring. In these cases, using diagonal cutting pliers, cut out the perforated openings on the left side of the drive front cover. Sharp edges along the cut out should be smoothed down with a file or sand paper to prevent any damage to the wires.

Route the communication wiring inside the enclosure for drives that do not require routing through the front cover. Refer to [Table 5](#) and [Figure 7](#) to determine the proper wire routing by drive model.

Table 5 Communication Wire Routing Selection

Drive Series	Model	Wire Routing <1>	
		Through Front Cover	Inside Drive
P1000	CIMR-PU2A0004 to 0040; CIMR-PU4A0002 to 0023; CIMR-PU5A0003 to 0011	<i>Figure 7 (A)</i>	-
	CIMR-PU2A0056 and above; CIMR-PU4A0031 and above; CIMR-PU5A0023 and above	-	<i>Figure 7 (B)</i>
iQpump1000	CIMR-PW2A0004 to 0040; CIMR-PW4A0002 to 0023; CIMR-PW5A0003 to 0011	<i>Figure 7 (A)</i>	-
	CIMR-PW2A0056 and above; CIMR-PW4A0031 and above; CIMR-PW5A0023 and above	-	<i>Figure 7 (B)</i>

<1> Refer to **Figure 7** for examples of the different wire routing techniques.

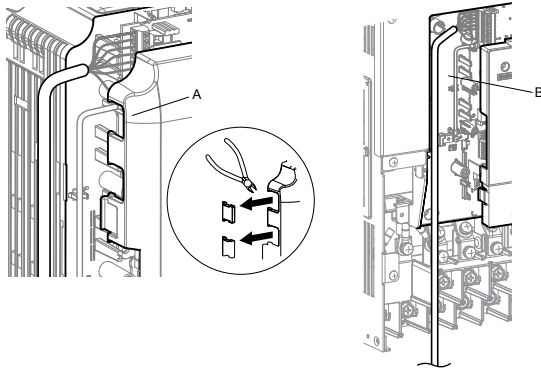

A – Route wires through the openings provided on the left side of the front cover. <1>

B – Use the open space provided inside the drive to route option wiring.

Figure 7 Wire Routing Examples

<1> The drive will not meet NEMA Type 1 requirements if wiring is exposed outside the enclosure.

- 2.** Connect the network communication cables to the option modular connector terminal block (TB1).

Note: Separate the communications cables from the main circuit cables and other wiring and power cables. Use properly grounded shielded cables for the communication cables to prevent problems caused by electrical interference.

5 Installation Procedure

■ Connection Diagram

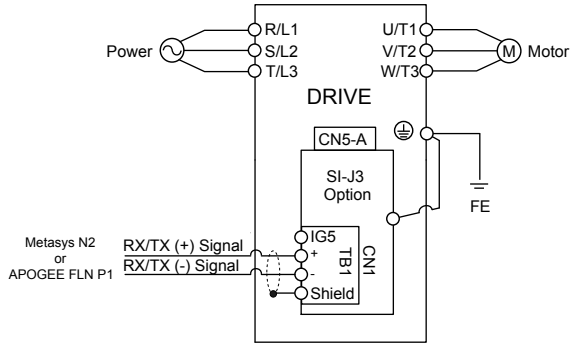

Figure 8 Connection Diagram

Figure 9 explains the wiring for multiple connections.

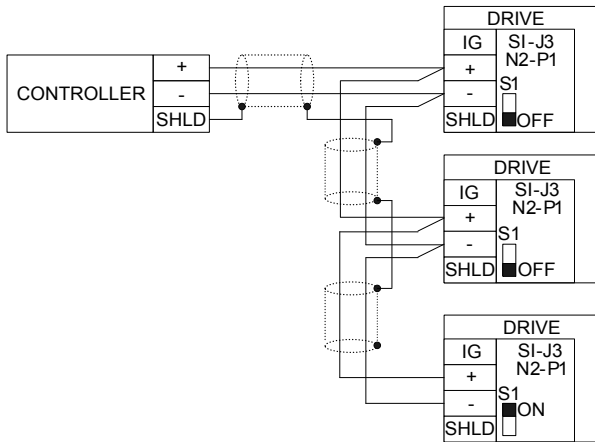

Figure 9 Connection Diagram for Multiple Connections

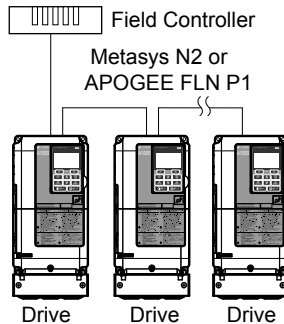

Figure 10 System Overview-Connecting Multiple Drives to the Network

The two ends of the network must be terminated with a 120 ohm resistor between the “+” and “-” and signals. The SI-J3 has a built in termination resistor that can be enabled or disabled using DIP switch S1. If a drive is located at the end of a network line, enable the termination resistor by setting DIP switch S1 to the ON position. Disable the termination resistor on all slaves that are not located at the end of the network line by setting DIP switch S1 to the OFF position (The factory setting for DIP switch S1 is OFF).

5 Installation Procedure

Replacing the Drive Covers and Digital Operator

1. Replace and secure the front covers of the drive (A, D) and replace the digital operator (B).

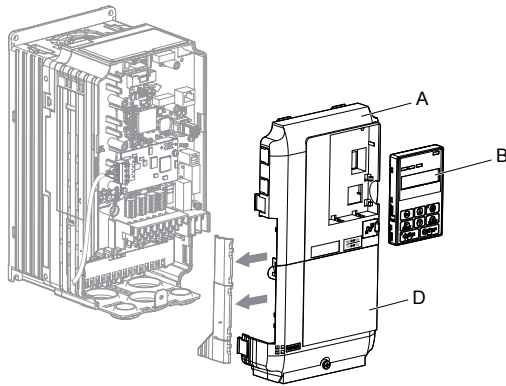

Figure 11 Replace the Front Covers and Digital Operator

Note: Take proper precautions when wiring the option so that the front covers will easily fit back onto the drive. Make sure no cables are pinched between the front covers and the drive when replacing the covers.

6 Related Drive Parameters

The following parameters are used to set up the drive for operation with the option. Parameter setting instructions can be found in the drive Quick Start Guide or Technical Manual.

Confirm proper setting of the all parameters in [Table 6](#) before starting network communications. After changing parameter settings, cycle power to the drive for the new settings to take effect.

Table 6 Related Parameters

No.	Name	Description	Values
b1-01 </>	Frequency Reference Selection	Selects the frequency reference input source. 0: Operator-Digital preset speed d1-01 to d1-17 1: Terminals-Analog input terminal A1 or A2 2: MEMOBUS/Modbus communications 3: Option PCB 4: Pulse Input (Terminal RP)	Default: 1 Range: 0 to 4 (Set to 3 for Metasys N2 or APOGEE FLN P1)
b1-02	Run Command Selection	Selects the run command input source. 0: Digital Operator-RUN and STOP keys 1: Digital input terminals S1 to S7 2: MEMOBUS/Modbus communications 3: Option PCB	Default: 1 Range: 0 to 3 (Set to 3 for Metasys N2 or APOGEE FLN P1)
F6-01 (3A2)	Operation Selection after Communications Error	Determines drive response when a bUS error is detected during communications with the option. 0: Ramp to Stop 1: Coast to Stop 2: Fast-Stop 3: Alarm Only	Default: 1 Range: 0 to 3
F6-02 (3A3)	External Fault Detection Conditions (EF0)	Sets the condition for external fault detection (EF0). 0: Always detected 1: Detected only during operation	Default: 0 Range: 0, 1
F6-03 (3A4)	Stopping Method for External Fault from the Communication Option	Determines drive response for external fault input (EF0) detection during option communications. 0: Ramp to Stop 1: Coast to Stop 2: Fast-Stop 3: Alarm Only	Default: 1 Range: 0 to 3
F6-08 (36A)	Reset Communication Related Parameters	Determines if communication-related parameters F6- and F7- are set back to original default values when the drive is initialized using parameter A1-03. 0: Do not reset parameters 1: Reset parameters	Default: 0 Range: 0, 1
F6-75	P1-N2 Protocol Select	1: N2 2: P1	Default: 2 Range: 1, 2
F6-76	P1-N2 Comm Fault Enable	0: Disabled 1: Enabled	Default: 1 Range: 0, 1
F6-77	P1-N2 Comm Fault Time	Seconds before declaring Comm Fault	Default: 2.0 0.0 to 10.0 Seconds

6 Related Drive Parameters

No.	Name	Description	Values
F6-78	P1-N2 Node Address	Network Node Address Network Physical Address	Default: 1 Range: 0 to 255
F6-79 <2>	P1 Baud Rate Select	2: 4800 3: 9600	Default: 3 Range: 2, 3

- <1> Set b1-02 to 3 to start and stop the drive with the option master device using serial communications. Set b1-01 to 3 to control the drive frequency reference via the master device.
- <2> N2 will always be set at 9600 Baud Rate.

Table 7 Option Monitors

No.	Name	Description	Values
U6-98	First Fault	First Option Fault	-
U6-99	Current Fault	Current Option Fault	-

7 Network Drive Operations

The drive operations that can be performed by Metasys N2 or APOGEE FLN P1 communication depend on drive parameter settings. This section explains the functions that can be used and related parameter settings.

◆ Observing the Drive Operation

A controller can perform the following actions with network communications at any time regardless of parameter settings:

- observe drive status and drive control terminal status from a controller
- read and write parameters
- set and reset faults
- set multi-function inputs.

Note: Input settings from the input terminals S□ and from network communications are both linked by a logical OR operation.

◆ Controlling the Drive

Select an external reference and adjust the parameters in [Table 8](#) accordingly to start and stop the drive or set the frequency reference using Metasys N2 or APOGEE FLN P1 communications.

Table 8 Setting Parameters for Drive Control from Metasys N2 or APOGEE FLN P1

Reference Source	Parameter	Name	Required Setting
External Reference 1	b1-01	Frequency Reference Selection 1	3
	b1-02	Run Command Selection 1	3
External Reference 2	b1-15	Frequency Reference Selection 2	3
	b1-16	Run Command Selection 2	3

8 Communications Timing

To prevent a communications overrun in the slave drive, the master should wait a certain time between sending messages to the same drive. Similarly, the slave drive must wait before sending response messages to prevent an overrun in the master. This section explains the message timing.

◆ Command Messages from Master to Drive

The master must wait for a specified time between receiving a response and resending the same type of command to the same slave drive to prevent overrun and data loss. The minimum wait time depends on the command as shown in [Table 9](#).

Table 9 Minimum Wait Time for Sending Messages

Example	Minimum Wait Time
<ul style="list-style-type: none"> Control command (Run, Stop) Write parameters Set inputs/outputs Read monitors and parameter values 	5 ms

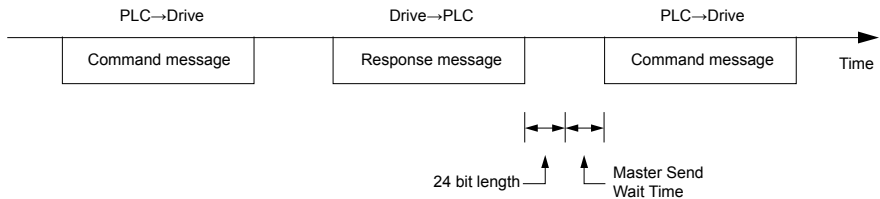

Figure 12 Minimum Wait Time for Sending Messages

Set a timer in the master to check how long it takes for the slave drive(s) to respond to the master. The master should try resending the message if no response is received within a certain amount of time.

◆ Response Messages from Drive to Master

The drive will process the data received and wait at least 5 ms before it responds if the drive receives a command from the master.

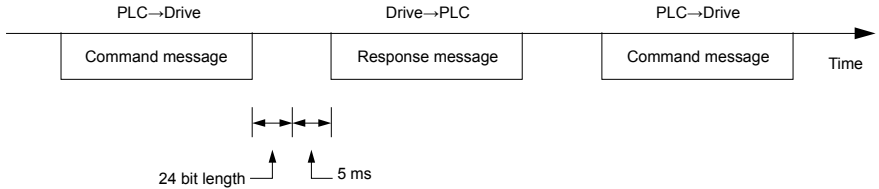

Figure 13 Minimum Response Wait Time

9 Metasys N2 Communications

◆ Drive Functions

Each of the following functions must be enabled during start-up of the drive:

■ Start and Stop the Drive

Set the Run Forward Command (BO 1) to run the drive in the forward direction. Set the Run Reverse Command (BO 2) to run the drive in the reverse direction. Run/Stop Monitor (BI 1) shows the current run status of the drive. Forward/Reverse Monitor (BI 2) shows the current direction.

NOTICE: *Damage to Equipment. Improper drive direction may damage HVAC equipment if parameter b1-04, Reverse Enable, is set to 0 (Enable). Confirm proper motor rotation prior to connecting the load to the motor.*

■ Lock the Drive Panel

Locking the panel prevents the user from using the LOCAL/REMOTE and STOP keys locally at the drive panel. Panel Lock (BO 10) can be commanded to lock and unlock the panel.

■ Digital Inputs

Multi-Function Input S3 (BO 5) through Multi-Function Input S7 (BO 9) are physical digital inputs on the drive. They can be set either by external devices, such as limit or pressure switches, or by the network. Their function depends on how the drive has been programmed. Refer to the drive manual section on Multi-Function Inputs (H1-03 through H1-07) for detailed information on the use and programming of the multi-function inputs. The multi-function input status can be monitored through Multi-Function Input 1 Monitor (BI 14) through Multi-Function Input 5 Monitor (BI 19). The multi-function inputs can be set by both external devices or over the network.

Note: The multi-function inputs can be set by both external devices or over the network. Use caution when connecting the multi-function inputs to external devices to ensure correct system operation.

■ Loop Gain

PI Proportional Gain (AO 4) and PI Integral Time (AO 5) are the gain and integral time parameters used by the drive. The PI loop is structured differently than the Metasys loop. Refer to the drive manual section on PID for information on how the PI loop functions.

■ Reading and Resetting Faults

The Fault Monitor (BI 4) and Drive Ready Monitor (BI 3) show the current status of the drive. The Fault Code (AI 10) contains the code for the most current fault. The LST Fault Code (AI 19) contains the code for the previous fault. *Refer to Drive Fault Trace Register Contents on page 51* for the purpose of interpreting fault codes. The drive faults can be reset through the Fault Reset Command (BO 4). The Fault Reset Command is only available when the Run Forward Command and the Run Reverse Command are both OFF.

Set a timer in the master to check how long it takes for the slave drive(s) to respond to the master. The master should try resending the message if no response is received within a certain amount of time.

◆ Metasys N2 Point Database

This section describes the Metasys N2 point database. This database features logical points: Analog Inputs (AI), Analog Outputs (AO), Binary Inputs (BI) and Binary Outputs (BO). These points configure, control, and monitor the operation of the drive.

■ Metasys N2 Analog Input (AI) Summary

Table 10 Metasys N2 Analog Input Summary (SI-J3 to Metasys N2)

Object ID	Object Name	Units	Yaskawa Drive Parameter
AI 1	Speed Reference	0.01 Hz	U1-01
AI 2	Output Sped	0.01 Hz	U1-02
AI 3	Output Current	0.1 A	U1-03
AI 4	kWatt Hour Meter	kWh	U4-10
AI 5	Output Power	0.1 kWh	U1-08
AI 6	Drive Temperature	1 °C	U4-08
AI 7	PI Feedback	0.01%	U5-01
AI 8	AC Output Voltage	0.1 Vac	U1-06
AI 9	DC Bus Voltage	1 Vdc	U1-07
AI 10	Fault Code	-	U2-01
AI 11	Elapsed Time - Hours	1 hour	U4-01
AI 12	Elapsed Time - 10K Hours	10K hours	U4-01
AI 13	MWatt Hour meter	MWh	U4-11
AI 14	Drive Rated Current	A	n9-01
AI 15	Communication Error Code	-	-
AI 16	PI Deviation	0.01%	U5-02
AI 17	PI Output Capacity	0.01%	U5-03
AI 18	PI Reference	0.01%	U5-04
AI 19	Last Fault Code	-	U2-02

9 Metasys N2 Communications

Object ID	Object Name	Units	Yaskawa Drive Parameter
AI 20	Freq Ref @ Fault	0.01 Hz	U2-03
AI 21	Output Freq @ Fault	0.01 Hz	U2-04
AI 22	Output Current @ Fault	0.1 A	U2-05
AI 23	Out Volt Ref @ Fault	0.1 Vac	U2-07
AI 24	DC Bus Volts @ Fault	1 Vdc	U2-08
AI 25	Output Power @ Fault	0.1 kW	U2-09
AI 26	Input Term Status @ Fault	-	U2-11
AI 27	Output Term Status @ Fault	-	U2-12
AI 28	Operation Status @ Fault	-	U2-13
AI 29	Elapsed Operation Time @ Fault	1 hour	U2-14
AI 30	Most Recent Fault	-	U3-01
AI 31	2nd Most Recent Fault	-	U3-02
AI 32	3rd Most Recent Fault	-	U3-03
AI 33	4th Most Recent Fault	-	U3-04
AI 34	Elapsed Time @ Current Fault	1 hour	U3-11
AI 35	Elapsed Time @ 2nd Fault	1 hour	U3-12
AI 36	Elapsed Time @ 3rd Fault	1 hour	U3-13
AI 37	Elapsed Time @ 4th Fault	1 hour	U3-14
AI 38	Read Parameter Data	-	-

Metasys N2 Analog Output (AO) Summary

Table 11 Metasys N2 Analog Output Summary (Metasys N2 to SI-J3)

Object ID	Object Name	Units	Default Value	Yaskawa Drive Parameter
AO 1	Speed Command	0.01 Hz	-	-
AO 2	Acceleration Time	seconds	30.0	C1-01
AO 3	Deceleration Time	seconds	30.0	C1-02
AO 4	PI Proportional Gain	-	2.00	b5-02
AO 5	PI Integral Time	seconds	5.0	b5-03
AO 6	Stall Prevention Level – Run	%	120	L3-06
AO 7	Stall Prevention Level – Accel	%	120	L3-02
AO 8	Reference Operation Mode Select	-	1	b1-01
AO 9	Run Operation Mode Select	-	1	b1-02
AO 10	PI Mode Select	-	0	b5-01
AO 11	Frequency Command Upper Limit	% of Max	100.0	d2-01
AO 12	Frequency Command Lower Limit	% of Max	0.0	d2-02

Object ID	Object Name	Units	Default Value	Yaskawa Drive Parameter
AO 13	Motor Rated Current	A	Motor model dependent	E2-01
AO 14	Jump Frequency 1	0.1 Hz	0.0	d3-01
AO 15	Jump Frequency 2	0.1 Hz	0.0	d3-02
AO 16	Jump Frequency 3	0.1 Hz	0.0	d3-03
AO 17	Jump Frequency Bandwidth	0.1 Hz	1.0	d3-04
AO 18	Number of Auto Restarts	-	0	L5-01
AO 19	Operator Display Mode	-	0	o1-03
AO 20	Power Loss Ride-Thru	seconds	Drive model dependent	L2-02
AO 21	Cable Loss Timeout	seconds	2.0	F6-77
AO 22	Cable Loss Speed	0.01 Hz	0.00	d1-04
AO 23	PI Integral Limit	0.1%	100.0	b5-04
AO 24	PI Upper Limit Value	0.1	100.0	b5-06
AO 25	PI Offset Adjustment	0.1	0.0	b5-07
AO 26	PI Primary Delay Time	0.01	0.00	b5-08
AO 27	PI Feedback Reference Missing Detection Select	1	0	b5-12
AO 28	PI Feedback Reference Missing Detection Level	1%	0	b5-13
AO 29	PI Feedback Reference Missing Detection Time	0.1 s	1.0	b5-14
AO 30	Read Parameter Number	-	-	-
AO 31	Write Parameter Number	-	-	-
AO 32	Write Parameter Data	-	-	-

■ Metasys N2 Binary Input (BI) Summary

Table 12 Metasys N2 Binary Input Summary (SI-J3 to Metasys N2)

Object ID	Object Name	Default	Off (0) State	On (1) State
BI 1	Run/Stop Monitor	0	Stopped	Running
BI 2	Forward/Reverse Monitor	0	Forward	Reverse
BI 3	Drive Ready Monitor	0	Not Ready	Ready
BI 4	Fault Monitor	0	Not Faulted	Faulted
BI 5	Zero Speed	0	Not Zero Speed	Zero Speed
BI 6	Speed Agree	0	Not Speed Agree	Speed Agree
BI 7	Minor Fault	0	No Minor Fault	Minor Fault
BI 8	Major Fault	0	No Major Fault	Major Fault
BI 9	Drive Communication Error Monitor	0	No Error	Error

9 Metasys N2 Communications

Object ID	Object Name	Default	Off (0) State	On (1) State
BI 10	Multi-Function Output 1 (H2-01)	0	Off	On
BI 11	Multi-Function Output 2 (H2-02)	0	Off	On
BI 12	Multi-Function Output 3 (H2-03)	0	Off	On
BI 13	Safety Interlock Monitor	0	Safety Clear Terminal 3 Closed	Safety Set Terminal 3 Open
BI 14	HAND/AUTO Reference Monitor	0	REMOTE	LOCAL
BI 14	Multi-Function Input S3 Monitor	0	Off	On
BI 16	Multi-Function Input S4 Monitor	0	Off	On
BI 17	Multi-Function Input S5 Monitor	0	Off	On
BI 18	Multi-Function Input S6 Monitor	0	Off	On
BI 19	Multi-Function Input S7 Monitor	0	Off	On

■ Metasys N2 Binary Output (BO) Summary

Table 13 Metasys N2 Binary Output Summary (Metasys N2 to SI-J3)

Object ID	Object Name	Default	Off (0) State	On (1) State
BO 1	Run Forward Command	0	Stop	Forward
BO 2	Run Reverse Command	0	Stop	Reverse
BO 3	Serial Fault (EF0) Command	0	No Fault	Fault
BO 4	Fault Reset Command	0	No Reset	Reset
BO 5	Multi-Function Input S3 (H1-03)	0	Off	On
BO 6	Multi-Function Input S4 (H1-04)	0	Off	On
BO 7	Multi-Function Input S5 (H1-05)	0	Off	On
BO 8	Multi-Function Input S6 (H1-06)	0	Off	On
BO 8	Multi-Function Input S7 (H1-07)	0	Off	On
BO 10	Panel Lock	0	LOCAL/REMOTE and Stop/Reset Keys Enabled	LOCAL/REMOTE and Stop/Reset Keys Disabled
BO 11	Communication Fault Enable	0	BUS Fault Not Activated if Cable Loss Occurs	BUS Fault Activated if Cable Loss Occurs

◆ Metasys N2 Cable Loss Configuration and Behavior

This section describes the configurable cable loss feature of the drive. This feature offers a user maximum flexibility in determining drive response to a loss of communication.

■ Drive Behavior at Loss of Communication

The drive can be configured to respond to an interval without receipt of a message in one of the following methods:

- Continue at last speed
- Continue at last speed with alarm
- Continue at preset speed
- Ramp to Stop with EF0 fault
- Coast to Stop with EF0 fault
- Emergency Stop with EF0 fault

■ Metasys N2 I/O

Three Metasys N2 outputs are used to select the desired behavior:

- AO 21 -Cable Loss Timeout
- AO 22 -Cable Loss Speed
- BO 11 -Communication Fault

Table 14 Cable Loss Behavior Summary

Behavior	F6-01	Cable Loss Timeout (AO 21)	Cable Loss Speed (AO 22)	Communication Fault Enable (BO 11)
Decelerate to stop (stop time in C1-02) BUS fault	0	Timeout Interval	X	On
Coast to stop BUS fault	1	Timeout Interval	X	On
Emergency stop (stop time in C1-09) BUS fault	2	Timeout Interval	X	On
Continue at last speed	3	0	X	X
Continue at last speed with alarm	3	Timeout Interval	X	On
Continue at preset speed with alarm </>	4	Timeout Interval	Preset Speed	On

<1> Not all drives support setting F6-01=4.

- Note:**
1. Communication must first be established and then lost for these features to function as described. A communications timeout does not occur if a drive is powered-up without a cable connected or with the master controller offline.
 2. A run command must have been issued (BO 1=ON or BO 2=ON) prior to loss of communications for modes that describe the drive running after a communications timeout. The drive will not automatically restart from a stopped condition for safety purposes. Additional external wiring is required (consult factory) if a user requires the drive to restart automatically.

A BUS fault will be declared and will remain until communication is restored upon expiration of the communications timeout interval.

■ Continue at Last Speed

Cable Loss Timeout (AO 21) is set to 0, disabling the cable loss feature in this mode. The other two settings Cable Loss Speed (AO 22) and Communication Fault Enable (BO 11) are ignored. The drive simply maintains its last commanded state if communication is lost. The drive will not display an alarm or fault to indicate it has lost communication. This behavior can also be achieved by setting parameter F6-01 to 3. The drive will display an alarm and continue running. The Communication Fault Enable (BO 11) must be enabled and Cable Loss Timeout (AO 21) should be set to a value other than 0 for this specific condition.

■ Continue at Preset Speed

Cable Loss Timeout (AO 21) is set to the desired interval, Cable Loss Speed (AO 22) is set to the desired preset speed and F6-01 is set to 4 in this mode. The drive speed command (AO 1) is set to the Cable Loss Speed (AO 22) and the drive continues running at this new speed if the time between messages exceeds the timeout interval. Communication Fault Enable (BO 11) must be set to ON.

■ Stop with Fault (BUS)

Communication Fault Enable (BO 11) must be set to ON. Cable Loss Timeout (AO 21) is set to the desired interval and parameter F6-01 is set to a value of 0,1 or 2 in this mode. If the time between messages exceeds the timeout interval, the drive will declare a BUS fault and the drive speed command (AO 1) will be set to 0. The stopping method is determined by the setting of F6-01.

- F6-01=0 selects Ramp to Stop. The deceleration time or the slope of the ramp is determined by the setting of drive parameter C1-02.
- F6-01=1 selects Coast to Stop. The drive does not attempt to control the rate of deceleration.
- F6-01=2 selects Emergency or Fast Stop. The deceleration time is determined by the setting of drive parameter C1-09.

Note: The behavior of the drive at cable loss is controlled by parameter F6-01. This drive parameter works with the points as described in the table above to determine how the drive will respond to a cable loss. The drive will continue in its last state if the cable loss fault is disabled. The drive will continue to run at the last commanded frequency if running.

◆ Metasys N2 Mailbox Function

■ Reading Drive Parameters

Two points are defined for reading drive parameters:

- AO 30 - Specifies the parameter to be read from the drive.
- AI 38 - Reports the value of the parameter specified in AO 30.

The mailbox retrieves data from the parameter and sends it to the controller when this point is read.

Example: Writing a value of 387 (183 hex) to AO 30 specifies drive parameter b1-04. Reading AI 38 returns the current setting of parameter b1-04 to the controller.

■ Writing Drive Parameters

Two points are defined for writing drive parameters:

- AO 31 - Specifies the parameter to be written to.
- AO 32 - Entry location of the value to be written to the parameter specified in AO 31. The mailbox will write the value to the drive when this point is written. An ENTER or ACCEPT command does not need to be sent for the data to be taken by the drive. The behavior of the write is the same as with the digital operator. There are a limited number of drive parameters that can be written to when the drive is running.

Example: Writing a value of 387 (183 hex) to AO 31 specifies drive parameter b1-04. Writing a value of 1 to AO 32 sets b1-04 to 1 and enables the drive for reverse run.

10 APOGEE FLN P1 Communications

◆ Slope and Intercept Conversion

Several drive parameters are available for monitoring purposes. The available parameters include FREQ OUTPUT (Point 3), SPEED (Point 5), CURRENT (Point 6), TORQUE (Point 7), POWER (Point 8), DRIVE TEMP (Point 9), KWH (Point 10), and RUN TIME (Point 12). These points can be unbundled for monitoring or used in various global control strategies.

◆ Drive Controlled Feedback

The most typical application is Supervisory Control. The sensor for the control variable (e.g., water temperature) is hard-wired to the drive and the control device (fan) is modulated using the PI control loop built into the drive. The setpoint for the control variable (water temperature set point) is unbundled and commanded by the field panel, based on the building control strategy implemented in PPCL.

The point to unbundle and command for the set point is INPUT REF 1 (Point 60) when this strategy is used. The control variable (e.g., water temperature) can be monitored by unbundling PI FEEDBACK (Point 62). These points are provided in units of percent, where 0% and 100% correspond to the range of the sensor being used to measure the control variable. These points have default units in Hz. Unbundle these points with appropriate slopes and intercepts if other units are required. The new intercept will be equal to the lowest value of the desired range. The following formulas allow the user to define a new slope and intercept to convert the unit.

The following formulas allow the user to define a new slope and intercept to convert the unit.

$$\text{New Slope} = \frac{(\text{Desired Range}) \times (\text{Slope of Existing Point})}{(\text{Range of Existing Point})}$$

$$\text{New Slope} = \frac{(60 - 0) \text{ Hz} \times (0.01)}{(100 - 0)\%} = 0.006$$

■ Conversion Example

The drive is controlling a fan, which in turn is controlling the water temperature from a cooling tower. The temperature sensor has a range of -1 °C to +121 °C (30 °F to 250 °F). To unbundle the set point (INPUT REF 1), for commanding in degrees Fahrenheit, where 0 to 60 Hz is equal to -1 °C to +121 °C: New Intercept=30 (the temperature that corresponds to 0%).

$$\text{New Slope} = \frac{(\text{Desired Range}) \times (\text{Slope of Existing Point})}{(\text{Range of Existing Point})}$$

$$\text{New Slope} = \frac{(250 - 30) \text{ °F} \times (0.1)}{(100 - 0)\%} = 0.22$$

- Note:**
1. Desired Range=Range Maximum - Range Minimum
 2. Range of Existing Point=Existing Range Maximum - Existing Range Minimum

◆ Field Panel Controlled Feedback

The sensor is connected to the APOGEE FLN network at a remote location and the control loop is executed in PPCL using this strategy. The drive speed command is passed from the field panel to the drive by commanding INPUT REF 1 (Point 60).

NOTICE: *Damage to Equipment. Avoid using this strategy. This strategy is not recommended because it means that the loop is being closed over the network. Delays due to processor scan time and network traffic can cause control to be degraded or lost and damage to HVAC equipment may result.*

■ Unbundle the Feedback

Unbundling the feedback (PI FEEDBACK) for monitoring in degrees Fahrenheit:

New Intercept = 30

$$\text{New Slope} = \frac{(\text{Desired Range}) \times (\text{Slope of Existing Point})}{(\text{Range of Existing Point})}$$

$$\text{New Slope} = \frac{(250 - 30) \text{ } ^\circ\text{F} \times (0.1)}{(100 - 0)\%} = 0.022$$

- Note:**
1. Desired Range=Range Maximum - Range Minimum
 2. Range of Existing Point=Existing Range Maximum - Existing Range Minimum

◆ Other Functionalities

Enable the following functions during start-up of the drive:

■ Enable the Drive to Run

RUN ENABLE (Point 35) can be commanded to require the drive to have a physical input (Terminal S3) set before the drive can run. This works in conjunction with CMD RUN.STOP (Point 24) or the CMD REV.STOP (Point 22). If RUN ENABLE (Point 35) is commanded ON then terminal S3 needs to be on and CMD RUN.STOP (Point 24) or CMD REV.STOP (Point 22) needs to be commanded ON for the drive to run.

Alternately, RUN ENABLE (Point 35) is commanded OFF, then to run the drive CMD RUN.STOP (Point 24) or CMD REV.STOP (Point 22) is the only point that needs to be commanded ON.

■ Start and Stop the Drive

CMD RUN.STOP (Point 24) can be commanded to run the drive in the forward direction. STOP.RUN (Point 23) shows the current status of the drive.

■ Change Directions

CMD REV.STOP (Point 22) can be commanded to run the drive in the reverse direction. FWD.REV (Point 21) shows the current direction of the drive rotation.

NOTICE: *Damage to Equipment. Improper drive direction may damage HVAC equipment if parameter b1-04, Reverse Enable, is improperly set (b1-04=0). Confirm proper motor rotation prior to connecting the load to the motor.*

■ Lock the Drive Panel

Locking the panel prevents the user from using the LOCAL/REMOTE and STOP keys locally at the drive panel. LOCK PANEL (Point 33) can be commanded to lock and unlock the panel.

■ Digital Outputs

MULTI OUT 1 (Point 40), MULTI OUT 2 (Point 41), and MULTI OUT 3 (Point 42) are physical digital outputs on the drive. Their purpose depends on how the drive has been set-up. The drive can be programmed so that these points can display various limits, warnings, and status conditions. Some examples include frequency limit, over current, and motor over temperature fault.

■ Loop Gain

PID P GAIN (Point 63) and PID I TIME (Point 64) are the gain and integral time parameters similar to the P and I gains in the APOGEE FLN Terminal Equipment Controllers. The PI loop of the drive is structured differently than the Siemens loop, so there is not a one-to-one correspondence between the gains.

■ Reading and Resetting Faults

OK.FAULT (Point 93) shows the current status of the drive. FAULT CODE (Point 17) contains the code for the most current fault. LST FLT CODE (Point 66) contains the code for the previous fault. [Refer to APOGEE FLN PI Application 2721 Point Number Summary on page 39](#) for descriptions of the fault codes. The drive can be reset back to OK mode by commanding RESET FAULT (Point 94) to RESET. The RESET FAULT command is only available when the CMD RUN.STOP (Point 24) and CMD REV.STOP (Point 22) are both STOP.

◆ APOGEE FLN Point Database

This section shows the APOGEE FLN point database for Application 2721.

■ APOGEE FLN Point List Summary

This database is for APOGEE FLN Application 2721 and features logical points: Logical Analog Inputs (LAI), Logical Analog Outputs (LAO), Logical Digital Inputs (LDI) and Logical Digital Outputs (LDO). These points configure, control or monitor the operation of the drive.

Information to consider when referencing this table:

1. Points not listed are not used in this application.
2. A single value in a column means that the value is the same in English units and in SI units.
3. Point numbers that appear in bold type (e.g. **03**) can be unbundled at the field panel.

Table 15 APOGEE FLN P1 Application 2721 Point Number Summary

Point No.	Point Type	Point Name	Factory Default (SI Units)	Units (SI Units)	Slope (SI Units)	Intercept (SI Units)	On Text	Off Text	Parameter
01	LAO	CTRL ADDRESS	31	-	1	0	-	-	F6-78
02	LAO	APPLICATION	-	-	1	0	-	-	-
03	LAI	FREQ OUTPUT	0	Hz	0.01	0	-	-	U1-02
04	LAI	PCT OUTPUT	0	%	0.01	0	-	-	-
05	LAI	SPEED	0	RPM	1	0	-	-	-
06	LAI	CURRENT	0	A	0.01	0	-	-	U1-03
07	LAI	TORQUE	0	%	0.1	0	-	-	U1-09
08	LAI	POWER	0	kW	0.1	0	-	-	U1-08
09	LAI	DRIVE TEMP	0	° C/F	1	0	-	-	U4-08
10	LAI	DRIVE KWH	0	kWh	0.1	0	-	-	U4-10
11	LAI	MWH	0	MWh	1	0	-	-	U4-11
12	LAI	RUN TIME	0	h	1	0	-	-	U4-01
13	LAI	DC BUS VOLT	0	V	1	0	-	-	U1-07
14	LAI	AC OUT VOLT	0	V	0.1	0	-	-	U1-06
15	LAI	PAR N9.01	0	A	0.01	0	-	-	n9-01
16	LAI	RUN TIMEX10K	0	10Kh	1	0	-	-	U4-01
17	LAI	FAULT CODE	0	-	1	0	-	-	U2-01
18	LDI	MINOR FLT	NO FLT	-	1	0	FAULT	NO FLT	U1-12 (Bit 6)
19	LDI	MAJOR FLT	NO FLT	-	1	0	FAULT	NO FLT	U1-12 (Bit 7)
20	LAO	OVRD TIME	1	h	1	0	-	-	-
21	LDI	FWD.REV	FWD	-	1	0	REV	FWD	U1-12 (Bit 2)
22	LDO	CMD REV.STOP	STOP	-	1	0	REV	STOP	-
23	LDI	RUN.STOP	STOP	-	1	0	RUN	STOP	U1-12 (Bit 0)
24	LDO	CMD RUN.STOP	STOP	-	1	0	FWD	STOP	-

10 APOGEE FLN P1 Communications

Point No.	Point Type	Point Name	Factory Default (SI Units)	Units (SI Units)	Slope (SI Units)	Intercept (SI Units)	On Text	Off Text	Parameter
25	LDI	ZERO SPEED	OFF	-	1	0	ON	OFF	U1-12 (Bit 1)
26	LDI	SPEED AGREE	NO AGR	-	1	0	AGREE	NO AGR	U1-12 (Bit 4)
27	LDI	DRIVE READY	NOTRDY	-	1	0	READY	NOTRDY	U1-12 (Bit 5)
28	LDI	LOC.REM MON	REMOTE	-	1	0	LOCAL	REMOTE	-
29	LDO	DAY.NGT	DAY	-	1	0	NGT	DAY	-
30	LAO	CURRENT LMT	0	A	0.01	0	-	-	E2-01
31	LAO	ACCEL TIME	0	s	0.1	0	-	-	C1-01
32	LAO	DECEL TIME	0	s	0.1	0	-	-	C1-02
33	LDO	LOCK PANEL	UNLOCK	-	1	0	LOCK	UNLOCK	-
35 </>	LDO	RUN ENABLE	STOP	-	1	0	ENABLE	STOP	-
36	LAO	STALL PRE RN	90	%	1	30	-	-	L3-06
37	LAO	STALL PRE AC	120	%	1	0	-	-	L3-02
38	LAO	FREQ UP LIM	100	%	0.1	0	-	-	d2-01
39	LAO	FREQ LOW LIM	0	%	0.1	0	-	-	d2-02
40	LDI	MULTI OUT 1	OFF	-	1	0	ON	OFF	U1-11 (Bit 0)
41	LDI	MULTI OUT 2	OFF	-	1	0	ON	OFF	U1-11 (Bit 1)
42	LDI	MULTI OUT 3	OFF	-	1	0	ON	OFF	U1-11 (Bit 2)
43	LDI	SAFETY ILOCK	OFF	-	1	0	ON	OFF	U1-10 (Bit 2)
44	LDO	MF INP 1	OFF	-	1	0	ON	OFF	-
45	LDO	MF INP 2	OFF	-	1	0	ON	OFF	-
46	LDO	MF INP 3	OFF	-	1	0	ON	OFF	-
47	LDO	MF INP 4	OFF	-	1	0	ON	OFF	-
48	LDO	MF INP 5	OFF	-	1	0	ON	OFF	-
49	LAO	JUMP FREQ 1	0	Hz	0.1	0	-	-	d3-01
50	LAO	JUMP FREQ 2	0	Hz	0.1	0	-	-	d3-02
51	LAO	JUMP FREQ 3	0	Hz	0.1	0	-	-	d3-03
52	LAO	JUMP FREQ BW	0	Hz	0.1	0	-	-	d3-04
53	LAO	NUM AUTOSTRT	0	-	1	0	-	-	L5-01

10 APOGEE FLN P1 Communications

Point No.	Point Type	Point Name	Factory Default (SI Units)	Units (SI Units)	Slope (SI Units)	Intercept (SI Units)	On Text	Off Text	Parameter
54	LAO	POWER LOSS RT	0.1	s	0.1	0	-	-	L2-02
55	LAO	RUN OP MODE	1	-	1	0	-	-	b1-02
56	LAO	REF OP MODE	1	-	1	0	-	-	b1-01
57	LAO	OPER DISP MD	0	-	1	0	-	-	o1-03
58	LDI	MF IN 1 MON	OFF	-	1	0	ON	OFF	U1-10 (Bit 2)
59	LDI	MF IN 2 MON	OFF	-	1	0	ON	OFF	U1-10 (Bit 3)
60	LAO	INPUT REF 1	0	Hz	0.01	0	-	-	-
61	LAO	INPUT REF 2	0	Hz	0.01	0	-	-	d1-02
62	LAI	PID FEEDBACK	0	%	0.01	0	-	-	U5-01
63	LAO	PID P GAIN	2	-	0.01	0	-	-	b5-02
64	LAO	PID I TIM	0.5	s	0.1	0	-	-	b5-03
65	LDO	PID MODE SEL	DISABLE	-	1	0	ENABLE	DISABLE	b5-01
66	LAI	LST FLT CODE	0	-	1	0	-	-	U2-02
67	LAI	FREF.FLT	0	Hz	0.01	0	-	-	U2-03
68	LAI	OUT FREQ.FLT	0	Hz	0.01	0	-	-	U2-04
69	LAI	OUT CUR.FLT	0	A	0.01	0	-	-	U2-05
70	LAO	RD PARAM NUM	1	-	1	0	-	-	-
71	LAI	RD PARAM DAT	0	-	1	0	-	-	-
72	LAO	WR PARAM NUM	1	-	1	0	-	-	-
73	LAO	WR PARAM DAT	0	-	1	0	-	-	-
74	LDI	MF IN 3 MON	OFF	-	1	0	ON	OFF	U1-10 (Bit 4)
75	LAI	OUT VOLT.FLT	0	V	0.1	0	-	-	U2-07
76	LAI	DC BUS.FLT	0	V	1	0	-	-	U2-08
77	LAI	OUT PWR.FLT	0	kW	0.1	0	-	-	U2-09
78	LDI	MF IN 4 MON	OFF	-	1	0	ON	OFF	U1-10 (Bit 5)
79	LAI	PID DEVIATE	0	%	0.01	0	-	-	U5-02
80	LAO	PID I LIMIT	100	%	0.1	0	-	-	b5-04
81	LAO	PID UP LIMIT	100	%	0.1	0	-	-	b5-06
82	LAO	PID OFFS ADJ	100	%	0.1	-100	-	-	b5-07
83	LAO	PID PRI DTYM	0	s	0.1	0	-	-	b5-08
84	LAO	PID FB RMDS	0	-	1	0	-	-	b5-12

10 APOGEE FLN P1 Communications

Point No.	Point Type	Point Name	Factory Default (SI Units)	Units (SI Units)	Slope (SI Units)	Intercept (SI Units)	On Text	Off Text	Parameter
85	LAO	PID FB RMDL	0	%	1	0	-	-	b5-13
86	LAO	PID FB RMDT	1	s	0.1	0	-	-	b5-14
87	LAI	PID OUT CAP	0	%	0.01	0	-	-	U5-03
88	LAI	PID REF	0	%	0.01	0	-	-	U5-04
89	LAI	COMM ERR CD	0	-	1	0	-	-	U1-19
90	LDO	COMM FLT ENA	ENABLE	-	1	0	ENABLE	DISABLE	F6-76
91	LAO	CBL LOSS FRQ	0	Hz	0.01	0	-	-	d1-04
92	LAO	CBL LOSS TMR	2	s	0.1	0	-	-	F6-77
93	LDI	OK.FAULT	OK	-	1	0	FAULT	OK	U1-12 (Bit 7)
94	LDO	RESET FAULT	NO	-	1	0	RESET	NO	-
95	LDI	DRV COMM ERR	NO FLT	-	1	0	FAULT	NO FLT	-
96	LDO	EXTERNAL FLT	OK	-	1	0	FAULT	OK	-
97	LDI	MF IN 5 MON	OFF	-	1	0	ON	OFF	U1-10 (Bit 6)
99	LAI	ERROR STATUS	0	-	1	0	-	-	-

<1> Set H1-03 to 70 , Drive Enable2, for point 35 to work properly.

◆ APOGEE FLN P1 Cable Loss Configuration and Behavior

This section describes the configurable cable loss feature of the drive. This feature offers a user maximum flexibility in determining the drive response to a loss of communication.

■ Drive Behavior At Loss of Communication

The drive can be configured to respond in one of the following manners after some interval without receipt of a message:

- Continue at last speed
- Continue at last speed with Alarm
- Continue at preset speed
- Ramp to Stop with EF0 fault
- Coast to Stop with EF0 fault
- Emergency Stop with EF0 fault

■ APOGEE FLN P1 Points

Three APOGEE FLN points are used to select the desired behavior:

- POINT 92 - CBL LOSS TMR
- POINT 91 - CBL LOSS FRQ
- POINT 90 - COMM FLT ENA

Table 16 Cable Loss Behavior Summary

Behavior	F6-01 Setting	CBL LOSS TMR (Point 92)	CBL LOSS FRQ (Point 91)	COMM FLT ENA (Point 90)
Decelerate to stop (stop time in C1-02) BUS Fault	0	Timeout interval	X	On
Coast to stop BUS Fault	1	Timeout interval	X	On
Fast stop (stop time in C1-09) BUS Fault	2	Timeout interval	X	On
Continue at last speed	3	0	X	X
Continue at last speed with alarm	3	Timeout interval	X	On
Continue at preset speed with alarm <I>	4	Timeout interval	Preset speed	On

<I> Not all drives support setting F6-01=4.

- Note:**
1. Communication must first be established and then lost for these features to function as described. A communications timeout does not occur if a drive is powered-up without a cable connected or with the master controller offline.
 2. A Run command must have been issued (RUN ENABLE (Point 35)=ON and either CMD RUN.FWD (Point 22)=ON or CMD RUN.REV (Point 24)=ON) prior to loss of communications for modes which describe the drive running after a communications timeout. The drive will not automatically restart from a stopped condition for safety purposes. Additional external wiring is required to accomplish this (consult factory) if a user requires the drive to restart automatically.

A BUS fault will be declared and will remain until communication is restored upon expiration of the communications timeout interval.

Continue at Last Speed

CBL LOSS TMR (POINT 92) is set to 0, disabling the cable loss feature in this mode. The other two settings, CBL LOSS FRQ (POINT 91) and COMM FLT ENA (POINT 90), are ignored. The drive maintains its last commanded state if communication is lost. The drive will not display an alarm or fault to indicate it has lost communication. This behavior can also be achieved by setting parameter F6-01 to 3. The drive will display an alarm and continue running. The COMM FLT ENA (POINT 90) must be enabled and CBL LOSS TMR (POINT 91) should be set to a value other than 0 for this specific condition. A BUS drive alarm will be set.

Continue at Preset Speed

CBL LOSS TMR (POINT 92) is set to the desired interval, CBL LOSS FRQ (POINT 91) is set to the desired preset speed and F6-01 is set to 4 in this mode. The drive speed command, INPUT REF 1, (Point 60) is set to the CBL LOSS FRQ (POINT 91) and the drive continues running at this new speed. If the time between messages exceeds the timeout interval, COMM FLT ENA (POINT 90) must be set to ON.

Stop with Fault (BUS)

COMM FLT ENA (POINT 90) must be set to ON. CBL LOSS TMR (POINT 92) is set to the desired interval and parameter F6-01 is set to a value of 0, 1, or 2 in this mode. The drive will declare a BUS fault and drive's speed command, INPUT REF 1, (Point 60) is set to 0 if the time between messages exceeds the timeout interval. The stopping method is determined by the setting of F6-01.

- F6-01=0 selects Ramp to Stop. The deceleration time or the slope of the ramp is determined by the setting of drive parameter C1-02.
- F6-01=1 selects Coast to Stop. The drive does not attempt to control the rate of deceleration.
- F6-01=2 selects Fast Stop. The deceleration time is determined by the setting of drive parameter C1-09.

Note: The behavior of the drive at cable loss is controlled by parameter H5-04. This drive parameter works with the points as described in the table above to determine how the drive will respond to a cable loss. The drive will continue in its last state if running, the drive will continue to run at the last commanded frequency if the cable loss fault is disabled.

◆ APOGEE FLN P1 Mailbox Function

■ Reading a Drive Parameter

Two points are defined for reading any drive parameter:

- #70 Specifies the parameter to be read from the drive
- #71 Reports the value of the parameter specified in Point #70

The mailbox retrieves data from the parameter and sends it to the controller when this point is read.

Example: Writing a value of 387 (183H) to Point #70 specifies drive parameter b1-04. Reading Point #71 returns the current setting of parameter b1-04 to the controller.

■ Writing to a Drive Parameter

Two points are defined for writing to any drive parameter:

- #72 Specifies the parameter to be written to
- #73 Entry location of the value to be written to the parameter specified in Point #72

The mailbox will write the value to the drive when this point is written. An ENTER or ACCEPT command does not need to be sent for the data to be taken by the drive. The behavior of the write is the same as with the digital operator. There are a limited number of drive parameters that can be written if the drive is running.

Example: Writing a value of 387 (183H) to Point #72 specifies drive parameter b1-04. Writing a value of 1 to Point #73 enables the drive for reverse run.

11 Troubleshooting

◆ Drive-Side Error Codes

Drive-side error codes appear on the drive digital operator. Causes of the errors and corrective actions are listed below. Refer to the drive manual for additional error codes that may appear on the drive digital operator.

■ Faults

Both BUS (SI-J3 option communication error) and EF0 (External fault input from the SI-J3 option) can appear as an alarm or as a fault. The digital operator ALM LED remains lit when a fault occurs. The ALM LED flashes when an alarm occurs.

Use the following questions as a guide to help remedy the fault if communication stops while the drive is running:

- Is the option properly installed?
- Are the communication lines properly connected to the option? Are the wires loose?
- Is the controller program working? Has the controller/PLC CPU stopped?
- Did a momentary power loss interrupt communications?

Digital Operator Display		Fault Name
BUS	BUS	Option Communication Error
		<ul style="list-style-type: none"> • The connection was lost after establishing initial communication. • Only detected when the run command frequency reference is assigned to an option card.
Cause		Possible Solution
No signal was received from the PLC		<ul style="list-style-type: none"> • Check for faulty wiring. • Correct the wiring.
Faulty communications wiring or an existing short circuit		<ul style="list-style-type: none"> • Check for disconnected cables and short circuits and repair as needed.
Communication data error occurred due to electrical interference		<ul style="list-style-type: none"> • Check the various options available to minimize the effects of noise. • Counteract noise in the control circuit, main circuit, and ground wiring. • Ensure that other equipment such as switches or relays do not cause electrical interference. Use surge absorbers if necessary. • Use only recommended cables or other shielded line. Ground the shield on the controller side or the drive input power side. • Separate all communication wiring from drive power lines. Install an EMC noise filter to the drive power supply input.
Communication timed out		<ul style="list-style-type: none"> • No network communications were received within the time set in parameter F6-77. Increase the setting of F6-77 or disable the fault using parameter F6-76.
The option card is damaged		Replace the option card if there are no problems with the wiring and the error continues to occur.

The option card is not properly connected to the drive	<ul style="list-style-type: none"> The connector pins on the option card do not line up properly with the connector pins on the drive. Reinstall the option card.
--	---

Digital Operator Display		Minor Fault Name
<i>EF0</i>	EF0	Option Card External Fault
		An external fault condition is present.
Cause		Possible Solutions
An external fault was received from the PLC with F6-03 set to 3, which allows the drive to continue running after an external fault occurs.		<ul style="list-style-type: none"> Remove the cause of the external fault. Remove the external fault input from the PLC.
There is a problem with the PLC program.		Check the PLC program and correct problems.

Digital Operator Display		Fault Name
<i>oFA00</i>	oFA00	Option Card Connection Error at Option Port CN5-A
		Option compatibility error
Cause		Possible Solution
The option card installed into port CN5-A is incompatible with the drive		Check if the drive supports the option card to be installed. Contact Yaskawa for assistance.
A PG option card is connected to option port CN5-A		PG option cards are supported by option ports CN5-B and CN5-C only. Connect the PG option card to the correct option port.

Digital Operator Display		Fault Name
<i>oFA01</i>	oFA01	Option Card Fault at Option Port CN5-A
		Option not properly connected
Cause		Possible Solution
The option card connection to port CN5-A is faulty		<ul style="list-style-type: none"> Turn off the power and reconnect the option card. Check if the option card is properly plugged into the option port. Make sure the card is fixed properly. If the option is not a communication option card, try to use the card in a different option port. If the option card works properly in a different option port, CN5-A is damaged, and the drive requires replacement. If the error persists (oFb01 or oFC01 occur), replace the option card.

Digital Operator Display		Fault Name
<i>oFA03 to oFA06</i>	oFA03 to oFA06	Option Card Error Occurred at Option Port CN5-A
<i>oFA10, oFA11</i>	oFA10, oFA11	

11 Troubleshooting

oFA12 to oFA17	oFA12 to oFA17	Option Card Connection Error (CN5-A)
oFA30 to oFA43	oFA30 to oFA43	Communication Option Card Connection Error (CN5-A)
Cause		Possible Solution
Option card or hardware is damaged		<ul style="list-style-type: none"> • Cycle power to the drive. • If the problem continues, replace the control board or the entire drive. Contact Yaskawa or a Yaskawa representative for instructions on replacing the control board.

Digital Operator Display		Fault Name
oFb00	oFb00	Option Card Fault at Option Port CN5-B
		Option compatibility error
Cause		Possible Solution
The option card installed into port CN5-B is incompatible with the drive		Make sure the drive supports the option card to be installed. Contact Yaskawa for assistance.
A communication option card has been installed in option port CN5-B		Communication option cards are only supported by option port CN5-A. It is not possible to install more than one communication option.

Digital Operator Display		Fault Name
oFb02	oFb02	Option Card Fault at Option Port CN5-B
		Same type of option card is currently connected
Cause		Possible Solution
An option card of the same type is already installed in option port CN5-A		Except for PG options, only one of each option card type can only be installed simultaneously. Make sure only one type of option card is connected.
An input option card is already installed in option port CN5-A		Install a communication option, a digital input option, or an analog input option. More than one of the same type of card cannot be installed simultaneously.

Digital Operator Display		Fault Name
oFC00	oFC00	Option Card Connection Error at Option Port CN5-C
		Option compatibility error
Cause		Possible Solution
The option card installed into port CN5-C is incompatible with the drive		Confirm that the drive supports the option card to be installed. Contact Yaskawa for assistance.
A communication option card has been installed in option port CN5-C		Communication option cards are only supported by option port CN5-A. It is not possible to install more than one communication option.

Digital Operator Display		Fault Name
oFC02	oFC02	Option Card Fault at Option Port CN5-C
		Same type of option card is currently connected
Cause		Possible Solution
An option card of the same type is already installed in option port CN5-A or CN5-B.		Except for PG options, only one of each option card type can only be installed simultaneously. Make sure only one type of option card is connected.
An input option card is already installed in option port CN5-A or CN5-B.		Install a communication option, a digital input option, or an analog input option. More than one of the same type of card cannot be installed simultaneously.
Three PG option boards are installed.		A maximum of two PG option boards can be used simultaneously. Remove the PG option board installed into option port CN5-A.

■ Minor Faults and Alarms

Digital Operator Display		Minor Fault Name
CALL	CALL	Serial Communication Transmission Error
		Communication has not yet been established.
Cause		Possible Solutions
Communications wiring is faulty, there is a short circuit, the wiring is incorrect , or the connections are poor.		<ul style="list-style-type: none"> • Check for wiring errors. • Correct the wiring. • Check for disconnected cables and short circuits. Repair as needed.
Programming error on the master side.		Check communications at start-up and correct programming errors.
Communications circuitry is damaged.		<ul style="list-style-type: none"> • Perform a self-diagnostics check. • If the problem continues, replace either the control board or the entire drive. For instructions on replacing the control board, contact Yaskawa or your nearest sales representative.
Termination resistor setting is incorrect.		Install a termination resistor at both ends of a communication line. Set the internal termination resistor switch correctly on slave drives. Place DIP switch S1 to the ON position.

12 Option Error Codes

◆ Option Fault Monitors U6-98 and U6-99

The option can declare error/warning conditions via drive monitor parameters on the drive digital operator as shown in [Table 17](#).

Table 17 Option Fault Monitor Descriptions

Fault Condition	Fault Declared	Status Value (U6-98/U6-99)	Description
No Fault	n/a	0	No faults.
Force Fault	EF0	3	Network sent a message to force this node to the fault state.
Communication Loss Fault	BUS Error	1401	Network communication was established and is now lost.

Two drive monitor parameters, U6-98 and U6-99 assist the user in network troubleshooting.

- U6-98 displays the first declared fault since the last power cycle. U6-98 is only cleared upon drive power-up.
- U6-99 displays the present option status. U6-99 is cleared upon a network-issued fault reset and upon power-up.

Parameter U6-98 retains the original fault value and U6-99 stores the new fault status value if another fault occurs while the original fault is still active.

13 Option Compatibility

A limited number of options may be simultaneously connected to the drive depending on the type of option. Refer to [Table 18](#) for more information. More details can be found in the Options and Peripheral Devices chapter of the drive Technical Manual.

Table 18 Option Installation Compatibility

OptionConnector	Connector	Number of Possible Options
SI-C3, SI-J3, SI-N3, SI-P3, SI-S3, SI-EN3 etc. </>	CN5-A	1
PG-B3, PG-X3 etc.	CN5-B, C	2 </>
DO-A3, AO-A3, AI-A3, DI-A3 etc.	CN5-A, B, C	1

<1> The AI-A3 and DI-A3 options can be used to set the frequency reference or replace the drive analog inputs with higher resolution when installed in CN5-A. These options can only be used for monitoring when installed in CN5-B or CN5-C; their input levels will be displayed in U1-17 or U1-21 to U1-23.

■ Drive Fault Trace Register Contents

Table 19 Drive Fault Trace Register Contents

Fault Code	Fault Name	Fault Code	Fault Name
0002H	Undervoltage (Uv1)	001DH	Motor Overheat (PTC input) (oH3)
0003H	Control Power Supply Undervoltage (Uv2)	001EH	Digital Operator Connection (oPr)
0004H	Soft Charge Circuit Fault (Uv3)	001FH	EEPROM Write Error (Err)
0006H	Ground Fault (GF)	0020H	Motor Overheat (PTC input) (oH4)
0007H	Overcurrent (oC)	0021H	MEMOBUS/Modbus Communication Error (CE)
0008H	Overvoltage (ov)	0022H	Option Communication Error (bUS)
0009H	Heatsink Overheat (oH)	0027H	Option External Fault (EF0)
000AH	Heatsink Overheat (oH1)	0028H	PI Feedback Loss (FbL)
000BH	Motor Overload (oL1)	0029H	Undertorque Detection 1 (UL3)
000CH	Drive Overload (oL2)	002BH	High Slip Braking Overload (oL7)
000DH	Overtorque Detection 1 (oL3)	0030H	Hardware Fault (including oFx)
0010H	Braking Resistor Overheat (rH)	0036H	Output Current Imbalance (LF2)
0011H	External Fault at Input Terminal S3 (EF3)	0037H	Pullout Detection (Sto)
0012H	External Fault at Input Terminal S4 (EF4)	003BH	Too Many Speed Search Restarts (SEr)
0013H	External Fault at Input Terminal S5 (EF5)	0041H	PI Feedback Loss (FbH)
0014H	External Fault at Input Terminal S6 (EF6)	0042H	External Fault 1, Input Terminal S1 (EF1)
0015H	External Fault at Input Terminal S7 (EF7)	0043H	External Fault 2, Input Terminal S2 (EF2)
001BH	Input Phase Loss (PF)	0046H	Current Offset Fault (CoF)
001CH	Output Phase Loss (LF)	0047H	PLC Detection Error 1 (PE1)

13 Option Compatibility

Fault Code	Fault Name
0048H	PLC Detection Error 2 (PE2)
004DH	Output Voltage Detection Fault (voF)
0052H	Node Setup Fault (nSE)
005AH	Motor Underload Protection (UL6)
0083H	A/D Conversion Error (CPF02)
0084H	PWM Data Fault (CPF03)
0087H	EEPROM Memory Data Error (CPF06)
0088H	Terminal Board Connection Error (CPF07)
0089H	EEPROM Serial Communication Fault (CPF08)
008CH	RAM Fault (CPF11)
008DH	Flash Memory Circuit Exception (CPF12)
008EH	Watchdog Circuit Exception (CPF13)
008FH	Control Circuit Fault (CPF14)
0091H	Clock Fault (CPF16)
0092H	Timing Fault (CPF17)
0093H	Control Circuit Fault (CPF18)
0094H	Control Circuit Fault (CPF19)
0095H	Hardware Fault at Power Up (CPF20)
0096H	Hardware Fault at Communication Start Up (CPF21)
0097H	A/D Conversion Fault (CPF22)
0098H	PWM Feedback Fault (CPF23)
0099H	Drive Unit Signal Fault (CPF24)
009AH	Terminal Board is Not Properly Connected. (CPF25)
009BH	ASIC BB Circuit Error (CPF26)
009CH	ASIC PWM Setting Register Error (CPF27)
009DH	ASIC PWM Pattern Error (CPF28)
009EH	ASIC On-delay Error (CPF29)
009FH	ASIC BBON Error (CPF30)
00A0H	ASIC Code Error (CPF31)
00A1H	ASIC Start-up Error (CPF32)
00A2H	Watch-dog Error (CPF33)
00A3H	ASIC Power/Clock Error (CPF34)
00A4H	External A/D Converter Error (CPF35)
00A9H	Control Circuit Error (CPF40)
00AAH	Control Circuit Error (CPF41)
00ABH	Control Circuit Error (CPF42)

Fault Code	Fault Name
00ACH	Control Circuit Error (CPF43)
00ADH	Control Circuit Error (CPF44)
00AEH	Control Circuit Error (CPF45)
0101H	Option Compatibility Error (oFA00)
0102H	Option Not Properly Connected (oFA01)
0106H	A/D Conversion Error (oFA05)
0107H	Option Response Error (oFA06)
0111H	Option RAM Fault (oFA10)
0112H	Option Operation Mode Fault (SLMOD) (oFA11)
0113H	Drive Receive CRC Error (oFA12)
0114H	Drive Receive Frame Error (oFA13)
0115H	Drive Receive Abort Error (oFA14)
0116H	Option Receive CRC Error (oFA15)
0117H	Option Receive Frame Error (oFA16)
0118H	Option Receive Abort Error (oFA17)
0131H	Comm. ID Error (oFA30)
0132H	Model Code Error (oFA31)
0133H	Sumcheck Error (oFA32)
0134H	Comm. Option Timeout Waiting for Response (oFA33)
0135H	MEMOBUS Timeout (oFA34)
0136H	Drive Timeout Waiting for Response (oFA35)
0137H	CI Check Error (oFA36)
0138H	Drive Timeout Waiting for Response (oFA37)
0139H	Control Command Selection Error (oFA38)
013AH	Drive Timeout Waiting for Response (oFA39)
013BH	Control Response Selection 1 Error (oFA40)
013CH	Drive Timeout Waiting for Response (oFA41)
013DH	Control Response Selection 2 Error (oFA42)
013EH	Control Response Selection Error (oFA43)
0401H	Time Not Set (TIM)
0402H	Operator Battery Low (bAT)
0403H	Time Data Error (TdE)
0404H	Time Interval Error (TiE)
0405H	Overvoltage 2 (ov2)
0407H	External Fan Fault (Fn1)

14 Specifications

Table 20 Option Specifications

Item	Specification
Model	SI-J3 option
Interface	RS-485
Connector Type	4-pin removable terminal block
Max Number of Drives	Metasys N2: 255 per N2 network segment APOGEE FLN P1: 127 per FLN network segment
Protocol	Metasys N2 APOGEE FLN P1
Communication Speed	Metasys N2: 9600 Baud APOGEE FLN P1: 4800 or 9600 Baud
Communication Parameters	Data Length: 8-bit Parity: None Stop Bit: 1
Ambient Temperature	-10 to +60 °C
Humidity	95% relative humidity (non-condensing)
Storage Temperature	-20 to +85 °C
Area of Use	Indoors
Altitude	1000 meters or lower With output current and voltage derating: up to 3000 meters

Revision History

The revision dates and the numbers of the revised manuals appear on the bottom of the back cover.

Date of Publication	Revision Number	Section	Revised Content
March 2013	-	-	First Edition

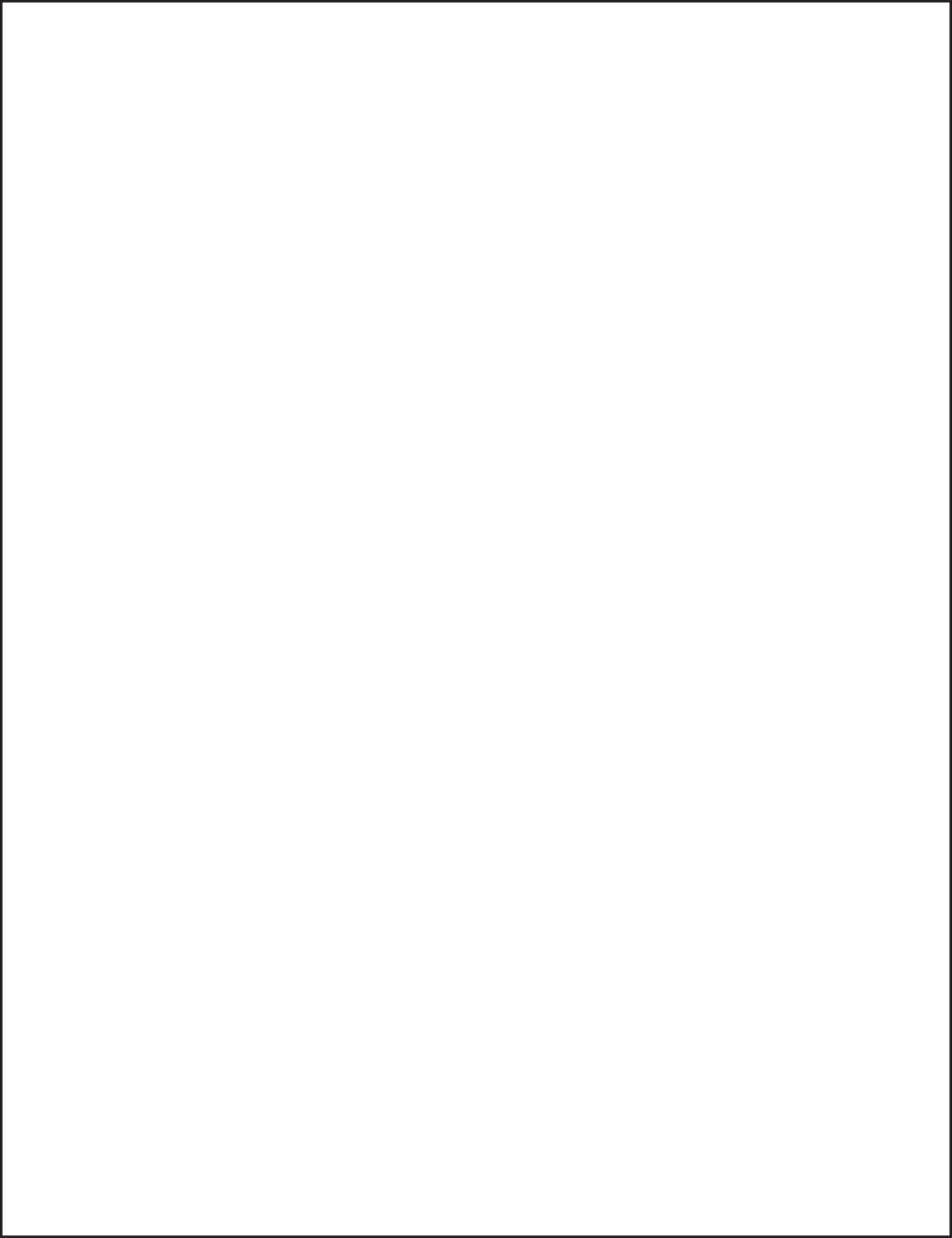

YASKAWA AC Drive - 1000-Series Option Metasys N2 & APOGEE FLN P1 Installation & Technical Manual

YASKAWA AMERICA, INC.

2121 Norman Drive South, Waukegan, IL 60085, U.S.A.
Phone: (800) YASKAWA (927-5292) or 1-847-887-7000 Fax: 1-847-887-7310
<http://www.yaskawa.com>

DRIVE CENTER (INVERTER PLANT)

2-13-1, Nishimiyaichi, Yukuhashi, Fukuoka, 824-8511, Japan
Phone: 81-930-25-3844 Fax: 81-930-25-4369
<http://www.yaskawa.co.jp>

YASKAWA ELECTRIC CORPORATION

New Pier Takeshiba South Tower, 1-16-1, Kaigan, Minatoku, Tokyo, 105-6891, Japan
Phone: 81-3-5402-4502 Fax: 81-3-5402-4580
<http://www.yaskawa.co.jp>

YASKAWA ELÉTRICO DO BRASIL LTDA.

Avenda Fagundes Filho, 620 Bairro Saude, São Paulo, SP04304-000, Brasil
Phone: 55-11-3585-1100 Fax: 55-11-5581-8795
<http://www.yaskawa.com.br>

YASKAWA EUROPE GmbH

Hauptstrasse 185, 65760 Eschborn, Germany
Phone: 49-6196-569-300 Fax: 49-6196-569-398
<http://www.yaskawa.eu.com>

YASKAWA ELECTRIC UK LTD.

1 Hunt Hill Orchardton Woods, Cumbernauld, G68 9LF, United Kingdom
Phone: 44-1236-735000 Fax: 44-1236-458182
<http://www.yaskawa.co.uk>

YASKAWA ELECTRIC KOREA CORPORATION

7F, Doore Bldg, 24, Yeoido-dong, Yeongdongpo-gu, Seoul, 150-877, Korea
Phone: 82-2-784-7844 Fax: 82-2-784-8495
<http://www.yaskawa.co.kr>

YASKAWA ELECTRIC (SINGAPORE) PTE. LTD.

151 Lorong Chuan, #04-01, New Tech Park, 556741, Singapore
Phone: 65-6282-3003 Fax: 65-6289-3003
<http://www.yaskawa.com.sg>

YASKAWA ELECTRIC (SHANGHAI) CO., LTD.

No. 18 Xizang Zhong Road, 17F, Harbour Ring Plaza, Shanghai, 200001, China
Phone: 86-21-5385-2200 Fax: 86-21-5385-3299
<http://www.yaskawa.com.cn>

YASKAWA ELECTRIC (SHANGHAI) CO., LTD. BEIJING OFFICE

Room 1011, Tower W3 Oriental Plaza, No. 1 East Chang An Ave.,
Dong Cheng District, Beijing, 100738, China
Phone: 86-10-8518-4086 Fax: 86-10-8518-4082

YASKAWA ELECTRIC TAIWAN CORPORATION

9F, 16, Nanking E. Rd., Sec. 3, Taipei, 104, Taiwan
Phone: 886-2-2502-5003 Fax: 886-2-2505-1280



YASKAWA AMERICA, INC.

In the event that the end user of this product is to be the military and said product is to be employed in any weapons systems or the manufacture thereof, the export will fall under the relevant regulations as stipulated in the Foreign Exchange and Foreign Trade Regulations. Therefore, be sure to follow all procedures and submit all relevant documentation according to any and all rules, regulations and laws that may apply. Specifications are subject to change without notice for ongoing product modifications and improvements.

© 2013 YASKAWA AMERICA, INC. All rights reserved.



TOEPYACOM13

MANUAL NO. TOEP YAICOM 13

Published in USA March 2013

